

**Modular Cooking Range Line
 thermaline 90 - Full Module
 Freestanding Gas Fry Top Mixed Plate, 1
 Side, Backsplash, H=800**

ITEM # _____

MODEL # _____

NAME # _____

SIS # _____

AIA # _____



589571 (MCHFFBHDPO) Gas Fry Top with smooth and ribbed chrome Plate, one-side operated with backsplash

Short Form Specification

Item No. _____

Unit constructed according to DIN 18860_2 with 20 mm drop nose top and 70 mm recessed plinth. Internal frame for heavy duty sturdiness in stainless steel. 2 mm top in 1.4301 (AISI 304). Flat surface construction, easily cleanable. THERMODUL connection system enables seamless worktop when units are connected and avoids soil penetrating. Chromium-plated mild steel cooking surface with non-stick finishing for optimal grilling. Stainless steel high splash guards on the rear and sides. Features safety thermostat, thermostatic control and led indication of pilot flame. Electrical ignition powered by battery with thermocouple for added safety. Large drain hole allows draining of cooking juices into a large collector. Overheat protection switches off the supply in case of overheating. Metal knobs with embedded hygienic silicon "soft" grip enable easier handling and cleaning. IPX5 water resistant certification.
 Configuration: Freestanding, One-side operated with backsplash.

Main Features

- Choice of one or two heating zones. An indicator lamp shows operating state of each zone.
- Large drain hole on cooking surface permits the draining of residual cooking juices into a large collector placed under the cooking surface.
- Overheat protection: the temperature sensor switches off the supply in case of overheating.
- Safety thermostat and thermostatic control.
- Stainless steel high splash guards on the rear and sides of cooking surface.
- Units have separate controls for each half module of the cooking surface.
- All major components may be easily accessed from the front.
- THERMODUL connection system creates a seamless work top when units are connected to each other thus avoiding soil penetrating vital components and facilitating the removal of units in case of replacement or service.
- Metal knobs with embedded hygienic "soft-touch" grip for easier handling and cleaning. The special design of the controls prevents infiltration of liquids or soil into vital components.
- Large visible digital display manufactured in tempered glass to resist heat and chemicals, showing temperatures or power settings. The display also shows on/off status of the appliance and on/off status of the heating elements.
- Electrical ignition powered by battery with thermocouple for added safety.
- Led indication of pilot flame

Construction

- 2 mm top in 1.4301 (AISI 304).
- Unit constructed according to DIN 18860_2 with 20 mm drop nose top and 70 mm recessed plinth.
- Flat surface construction with minimal hidden areas to easily clean all surfaces
- Cooking surface in chromium-plated mild steel with non-stick finishing for optimum grilling results.
- IPx4 water protection.
- Internal frame for heavy duty sturdiness in stainless steel.
- Cooking surface 2/3 smooth and 1/3 ribbed.

APPROVAL: _____



Optional Accessories

- Connecting rail kit for appliances with backsplash, 900mm PNC 912499
- Portioning shelf, 800mm width PNC 912526
- Portioning shelf, 800mm width PNC 912556
- Folding shelf, 300x900mm PNC 912581
- Folding shelf, 400x900mm PNC 912582
- Fixed side shelf, 200x900mm PNC 912589
- Fixed side shelf, 300x900mm PNC 912590
- Fixed side shelf, 400x900mm PNC 912591
- Stainless steel front kicking strip, 800mm width PNC 912598
- Stainless steel side kicking strips left and right, against the wall, 900mm width PNC 912624
- Stainless steel side kicking strips left and right, back-to-back, 1810mm width PNC 912627
- Stainless steel plinth, against wall, 800mm width PNC 912901
- Connecting rail kit for appliances with backsplash: modular 90 (on the left) to ProThermetic tilting (on the right), ProThermetic stationary (on the left) to ProThermetic tilting (on the right) PNC 912981
- Connecting rail kit for appliances with backsplash: modular 90 (on the right) to ProThermetic tilting (on the left), ProThermetic stationary (on the right) to ProThermetic tilting (on the left) PNC 912982
- Back panel, 800x800mm, for units with backsplash PNC 913026
- Stainless steel panel, 900x800mm, against wall, left side PNC 913102
- Stainless steel panel, 900x800mm, against wall, right side PNC 913106
- Endrail kit, flush-fitting, with backsplash, left PNC 913117
- Endrail kit, flush-fitting, with backsplash, right PNC 913118
- Scraper for smooth plates PNC 913119
- Scraper for ribbed plates PNC 913120
- Endrail kit (12.5mm) for thermaline 90 units with backsplash, left PNC 913208
- Endrail kit (12.5mm) for thermaline 90 units with backsplash, right PNC 913209
- U-clamping rail for back-to-back installations with backsplash (to be ordered as S-code) PNC 913226
- Insert profile d=900 PNC 913232
- Perforated shelf for warming cabinets and cupboard bases (one-side operated TL80-85-90 and two-side operated for TL80) PNC 913234
- Side reinforced panel only in combination with side shelf, for against the wall installations, left PNC 913268
- Side reinforced panel only in combination with side shelf, for against the wall installations, right PNC 913270

- Shelf fixation for TL80-85-90 one-side operated, TL80 two-side operated PNC 913281
- Stainless steel dividing panel, 900x800mm, (it should only be used between Electrolux Professional thermaline Modular 90 and thermaline C90) PNC 913673
- Stainless steel side panel, 900x800mm, flush-fitting (it should only be used against the wall, against a niche and in between Electrolux Professional thermaline and ProThermetic appliances and external appliances - provided that these have at least the same dimensions) PNC 913689
- Gas mainswitch for modular H800 gas units (factory fitted) PNC 913698

Recommended Detergents

- C41 HI-TEMP RAPID DEGREASER, 1 pack of six 1 lt. bottles (trigger incl.) PNC 0S2292



Electrolux
PROFESSIONAL

Modular Cooking Range Line
thermaline 90 - Full Module Freestanding Gas
Fry Top Mixed Plate, 1 Side, Backsplash, H=800

Front

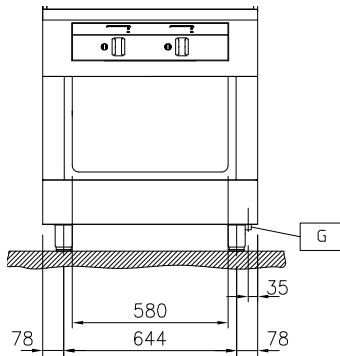

Side

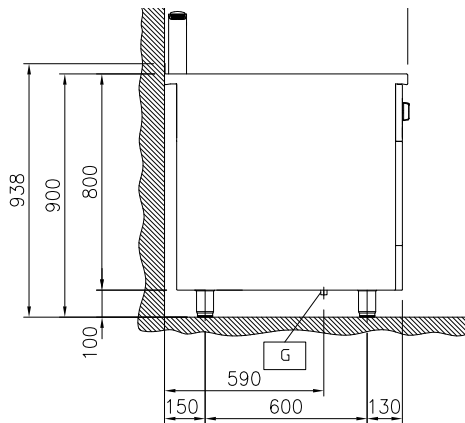

EQ = Equipotential screw
G = Gas connection

Top

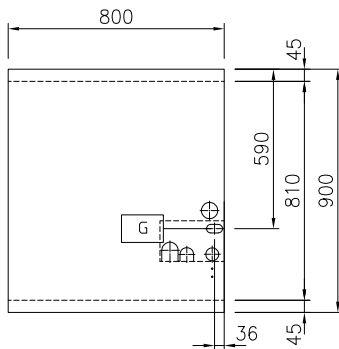

Gas

Gas Power:	20 kW
Gas Type Option:	
Gas Inlet:	1/2"

Key Information:

Cooking Surface Depth:	615 mm
Cooking Surface Width:	700 mm
Working Temperature MIN:	110 °C
Working Temperature MAX:	270 °C
External dimensions, Width:	800 mm
External dimensions, Depth:	900 mm
External dimensions, Height:	800 mm
Storage Cavity Dimensions (width):	580 mm
Storage Cavity Dimensions (height):	330 mm
Storage Cavity Dimensions (depth):	740 mm
Net weight:	150 kg
Configuration:	On Base; One-Side Operated
Cooking surface type:	half ribbed/ half smooth
Cooking surface - material:	Chromium Plated mild steel mirror



Modular Cooking Range Line
thermaline 90 - Full Module Freestanding Gas Fry Top Mixed Plate, 1
Side, Backsplash, H=800
The company reserves the right to make modifications to the products
without prior notice. All information correct at time of printing.